

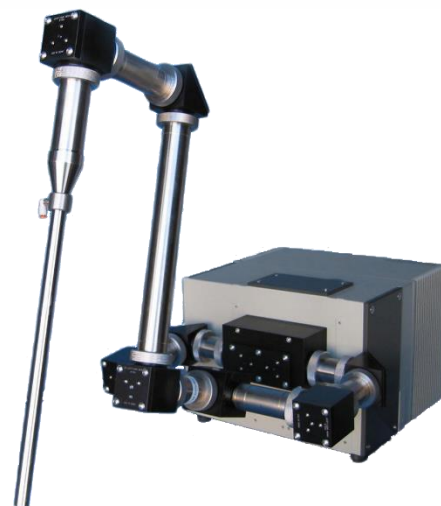

PS-DPR-207-DMD-270-Rev-E-(11-4-16)

DPR-207/DMD-270 SMALL DIAMETER ATR IMMERSION PROBES

Diamond-tipped and conventional probes for research and process development application



Models DPR-207 and DMD-270 feature excellent photometric accuracy and precision combined with the small diameter required for research and process development applications. The key to their high performance is the use of a single gold coated light guide combined with ATR element designs which precisely control the range of incidence angles and number of reflections at the sample interface. As a result, calibrations developed with these probes can be transferred between the two models or between these and Axiom's larger diameter, high transmission "process" probes with only a minor scaling adjustment.

DPR-207: VERSATILE PROBE FOR DIVERSE APPLICATIONS

The DPR-207 is a robust ATR probe employing interchangeable conical ATR elements in conjunction with nearly collimated IR radiation. This combination insures that all optical rays strike the sample interfacing surface within a range of $\pm 1^\circ$, resulting in a very high degree of response linearity and precision. The selection of standard element materials includes ZnSe, ZnS, AMTIR-1, silicon, and sapphire, allowing the probe characteristics to be altered as application requirements change.



DMD-270: DIAMOND-TIPPED PROBE FOR AGGRESSIVE CHEMESTRIES

The DMD-270 provides high performance throughout the mid-IR fingerprint region combined with the ability to stand up to strong acids, bases, and many other aggressive chemistries. In addition, its proprietary optical design insures that each ray experiences exactly three reflections at a well-defined angle of incidence, resulting in excellent accuracy and precision.

SPECTROMETER INTERFACING

Three different standard interfaces are available for coupling either a DPR-207 or a DMD270 to an FTIR spectrometer. Model DSR-207XY enables the probe to be coupled directly to the sample compartment of a conventional FTIR spectrometer. The suffixes X and Y are used to specify the spectrometer make and model. Model DSX-207 interfaces to Axiom's AXM-601 outboard sample module. This provides a high degree of flexibility in placement of the probe by allowing various combinations of Axiom mirror and conduit modules to be used between the sample module and the spectrometer. Finally, model DSD207XS couples the probe to a dedicated process FTIR spectrometer employing dual input and output beam ports. Whichever optical configuration is employed, the small diameter probes should be operated with a liquid nitrogen cooled detector for best performance.

SAMPLE INTERFACING

Single light guide probes are normally supplied with an O-ring sealed sliding tapered joint (24/40) to mate to a glass reaction vessel. For operation at elevated pressures, the probes can be provided with an optional welded-on flange or port fitting.

FEATURES:

- Small diameter
- Easily interfaced to any FTIR spectrometer
- Diamond element for excellent corrosion resistance (DMD-270)
- Interchangeable ATR elements to meet diverse requirements (DPR-207)
- Proprietary optical designs for maximum photometric accuracy and precision
- Robust construction for maximum reliability

U.S. PATENTS:

- 4,812,041
- 4,835,389
- 5,051,551
- 5,459,316
- 5,773,825



AXIOM'S COMPREHENSIVE IMMERSION PROBE PRODUCT LINE

Axiom Analytical pioneered the field of in-situ IR reaction monitoring with the introduction of the first ATR immersion probes in 1989. Since then, the company's immersion probe product lines have continued to expand to include ATR, transmission, diffuse reflectance, and Raman probes to meet virtually all applications. In addition to the DPR-207 and DMD-270, the company's ATR probe family includes the DPR-210 and 212 sample compartment mounted lab probes and the DRP-240, DMD-370, and DMD-373 high transmission process probes.

Specifications	DPR-207	DMD-270
Probe Diameter:	16 mm	16 mm
Immersion Depth:	30 cm	30 cm
ATR Reflections:	2 (See Note 1)	3
Angle of Incidence:	45° (See Note 1)	45°
Nominal Transmission	2-4 %	1-2%
Maximum Temperature:	280°C	200°C
Maximum Pressure:	See table below	30 bar
Wetted Metal:	316 stainless steel	Hastelloy C-276
Seal Type:	Energized, filled PTFE	Energized, filled PTFE

DPR-207 ATR ELEMENTS:

Material	Spectral Cutoff	Hardness (Knoop)	Attacked By	Max Pressure
ZnSe	600 cm ⁻¹	120	Acids, oxidizers	60 bar
ZnS	950 cm ⁻¹	250	Strong oxidizers, some acids	60 bar
AMTIR-1	850 cm ⁻¹	170	Strong alkalis	20 bar
Ge ²	700 cm ⁻¹	780	Hot sulphuric acid, aqua regia	50 bar
Sapphire ¹	2200 cm ⁻¹	1370	Concentrated acids and alkalis	100 bar
Silicon	1150 cm ⁻¹	1500	HF, HNO ₃ , NaOH	

Notes: 1. Sapphire elements provide three reflections at an incidence angle of 60°.
2. Ge elements are limited to < 100°C.

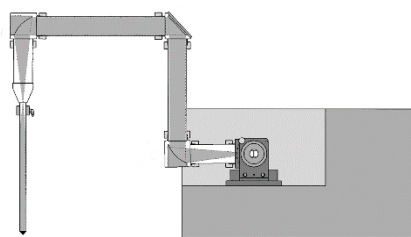

Figure 1: Cross-section of an inboard DMD-270 or DPR-207 system.

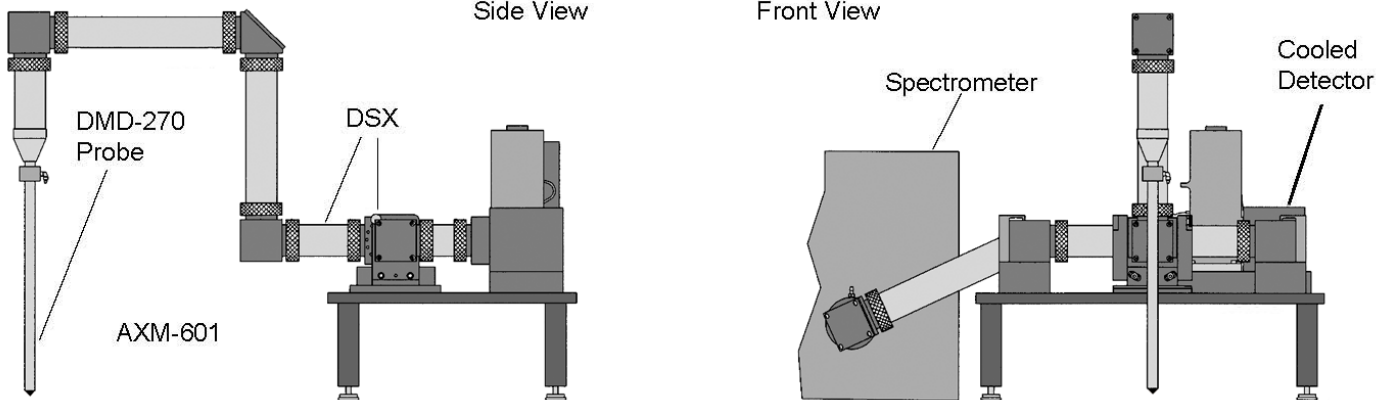

Figure 2: Front and side view of an outboard sampling configuration including a DSX-207 interface and AXM sampling stage.